

PUSH-QUICK FITTINGS

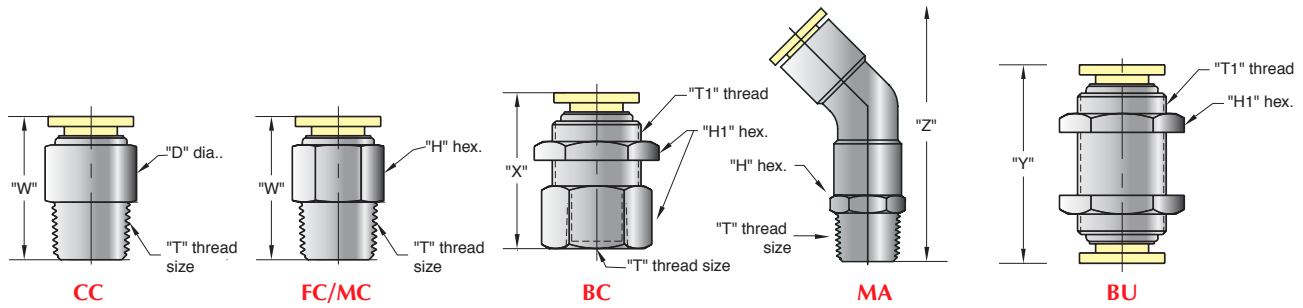

Tube Size	Thread Size "T"	"D"	"H"	"H1"	"T1"	"W"	"X"	"Y"	"Z"
1/8"	#10-32	0.410"			7/16"	0.880"			1.454"
1/8"	1/8" NPT	0.410"			7/16"	0.860"			1.474"
5/32"	#10-32	0.410"	7/16"		7/16"	0.890"	0.820"	0.440"	1.454"
5/32"	1/8" NPT	0.410"	7/16"	5/8"	7/16"	0.840"	0.920"	0.570"	1.474"
5/32"	1/4" NPT		9/16"			0.920"			
4 mm	M5 x 0.8		10 mm		10 mm	0.900"	0.830"	0.450"	1.454"
4 mm	R1/8		10 mm	14 mm	10 mm	0.840"	0.920"	0.563"	1.474"
6 mm	M5 X 0.8		12 mm		12 mm	0.950"	0.953"	0.500"	1.556"
6 mm	R1/8		10 mm	17 mm	12 mm	0.880"	0.976"	0.587"	1.556"
6 mm	R1/4		14 mm	17 mm	14 mm	0.875"	1.059"	0.654"	1.616"
1/4"	#10-32	0.470"	1/2"		1/2"	0.913"	0.940"	0.480"	1.620"
1/4"	1/8" NPT	0.470"	1/2"	3/4"	1/2"	0.913"	0.990"	0.600"	1.620"
1/4"	1/4" NPT	0.530"	9/16"	3/4"	9/16"	0.965"	1.120"	0.740"	1.682"
1/4"	3/8" NPT		11/16"		11/16"	0.965"			1.722"
5/16"	1/8" NPT	0.550"	9/16"	3/4"		1.09"	1.610"	1.390"	1.800"
5/16"	1/4" NPT	0.550"	9/16"	3/4"	5/8"	1.09"	1.610"	1.390"	1.800"
5/16"	3/8" NPT	0.670"	11/16"	3/4"	5/8"	1.09"	1.610"	1.390"	1.800"
8 mm	M5				5/8"	1.09"	1.610"	1.390"	1.800"
8 mm	R1/8	0.550"	14 mm	19 mm	5/8"	1.09"	1.610"	1.390"	1.800"
8 mm	R1/4	0.550"	14 mm	19 mm	5/8"	1.09"	1.610"	1.390"	1.800"
8 mm	R3/8	0.670"	17 mm	19 mm	5/8"	1.09"	1.610"	1.390"	1.800"
3/8"	1/8" NPT		11/16"		11/16"	1.280"			1.823"
3/8"	1/4" NPT	0.670"	11/16"	15/16"	11/16"	1.342"	1.320"	0.800"	1.923"
3/8"	3/8" NPT	0.670"	11/16"	15/16"	11/16"	1.241"	1.320"	0.900"	1.943"
1/2"	1/4" NPT		7/8"		7/8"	1.380"			1.965"
1/2"	3/8" NPT		7/8"		7/8"	1.320"			2.125"
1/2"	1/2" NPT		7/8"		7/8"	1.320"			2.195"

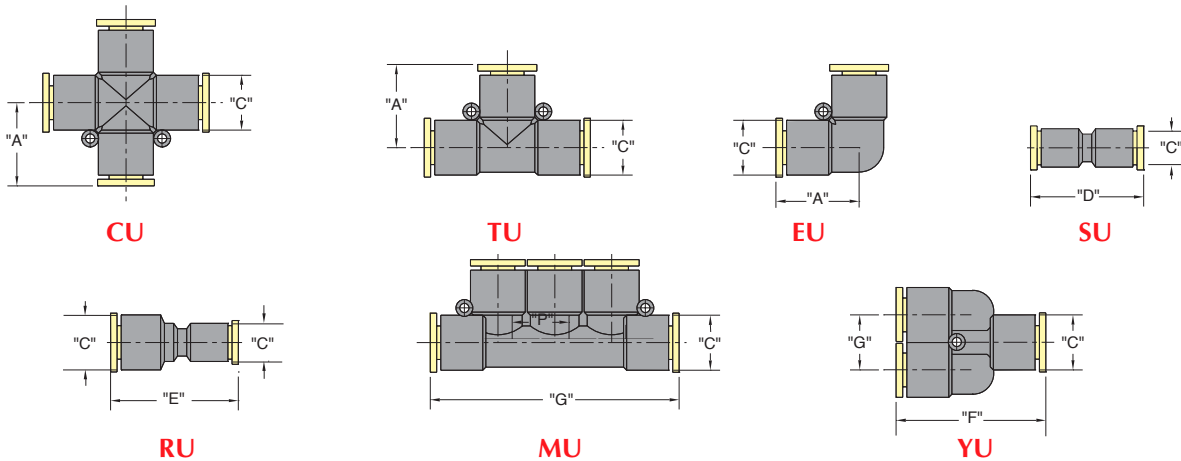

Tube Size	"A"	"C"	"D"	"E"	"F"	"G"
1/8"	0.710"	0.420"	1.240"			
5/32" / 4 mm	0.722"	0.410"	1.239"	1.230"	1.318"	2.312"
6 mm	0.830"	0.524"	1.500"	1.367"	1.495"	2.435"
1/4"	0.840"	0.524"	1.500"	1.666"	1.495"	2.435"
5/16" / 8 mm	0.880"	0.580"	1.540"	1.540"	1.495"	2.435"
3/8"	1.100"	0.720"	1.851"	1.666"	2.017"	2.312"
1/2"	1.130"	0.850"	1.810"	1.810"	2.070"	